

## CATALOG of STANDARD PROFILES

*AT CONTACT INDUSTRIES, OUR BUSINESS  
IS MAKING YOU LOOK SOLID.*

You can thank Mother Nature for giving us beautiful woods to work with. But you should thank the engineers at Contact Industries for developing beautiful wood moulding products that are easy to work with. Our Natural Wood Wrapped Mouldings and Jambs consist of clear grain real wood veneer laminated to a softer wood core that cuts and nails more easily, requires no pre-drilling and won't warp or split. They're available in cherry, maple, mahogany, oak or any other species and they come in 14-foot or 16-foot lengths, packaged and ready for easy installation. Piles of shorts are a thing of the past—all of our pieces come in premium lengths that builders and installers will love. They'll also appreciate less sanding, splicing and culling out defects. The truth is, Contact Industries' Natural Wood Wrapped Mouldings and Jambs are almost always superior to those made from solid wood, and that saves you time and money where it counts—at the bottom line.

### Casing

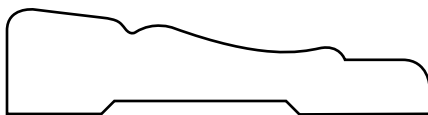

356  
1/2 x 2-1/8"



324  
1/2 x 2-1/4"



357  
11/16 x 2-1/4"

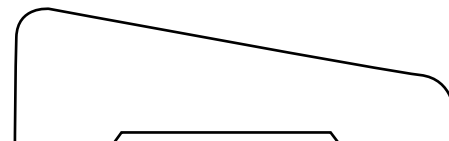

325  
11/16 x 2-1/4"



444  
11/16 x 3-1/4"

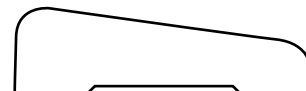

307  
7/16 x 1-1/2"

## Brick Mould

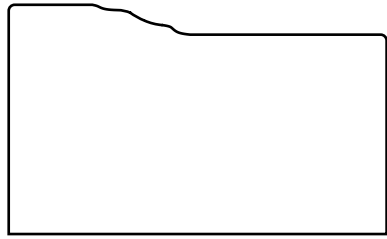

180  
1-1/4 x 2-1/8"

## Crown

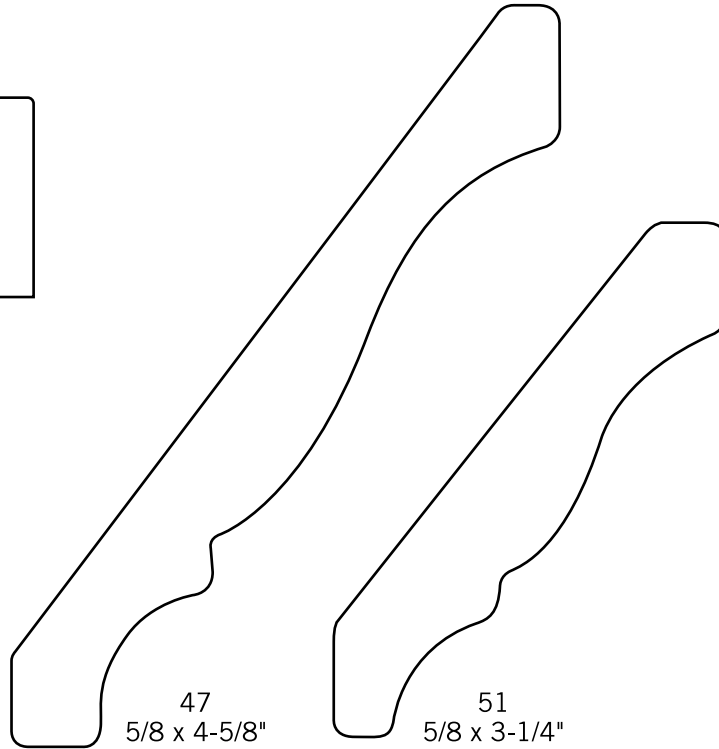

47  
5/8 x 4-5/8"

51  
5/8 x 3-1/4"

## Chair Rail

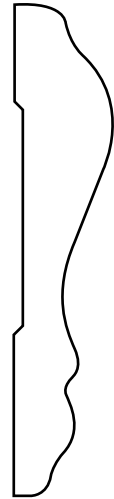

298  
1/2 x 2-1/2"

## Base Cap

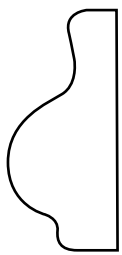

163  
9/16 x 1-1/4"

## Single Rabbett Frame

Interior and exterior frames available 4-9/16" up to 7-1/4".  
End sealing standard on all frames.

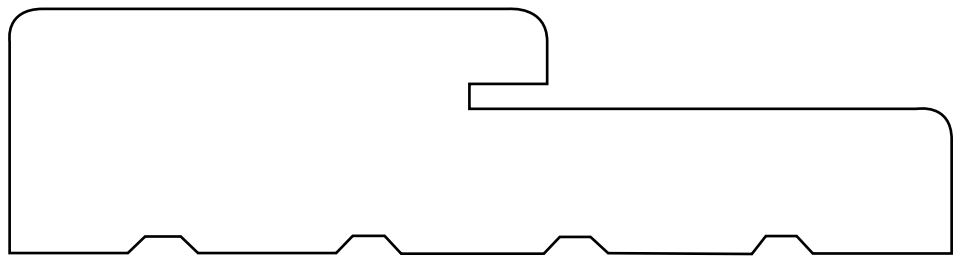

413  
1-1/4 x 4-13/16"

## Split Jamb

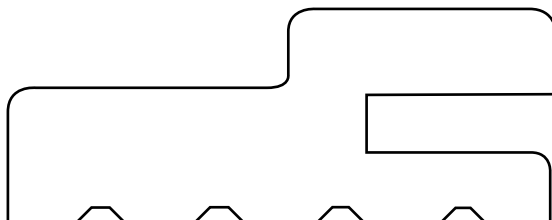

2913  
4-1/8 to 4-3/4"

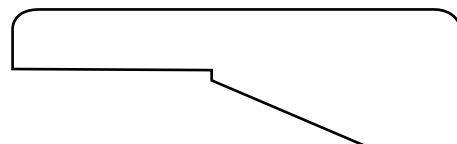

## Base



713  
9/16 x 3-1/4"



734  
3/8 x 2-1/2"



656  
3/8 x 2-3/4"

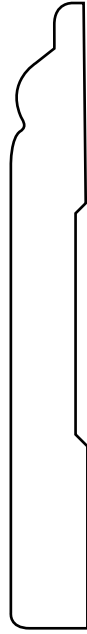

637  
3/8 x 3-1/4"

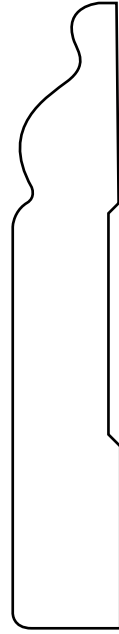

643  
9/16 x 3-1/4"

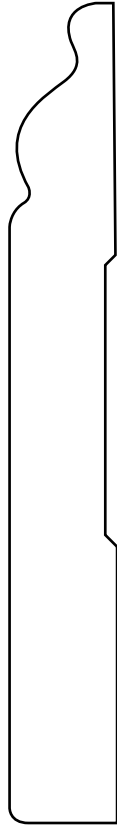

640  
9/16 x 4-1/4"

## Flat Jamb

Also available:

13  
11/16 x 4-13/16"

20  
11/16 x 5-1/4"



8  
11/16 x 4-9/16"

## Stop



917  
3/8 x 1-1/4"

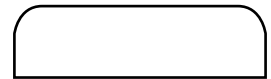

888  
3/8 x 1-1/4"

## S4S

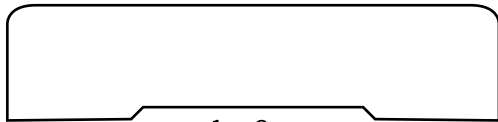

1 x 3  
5/8 x 2-1/2"

Also available:

1 x 2  
5/8 x 1-1/2"

1 x 4  
5/8 x 3-1/2"



1 x 8  
11/16 x 7-1/4"

## Build Ups

Add the elegance of larger moulding profiles by creating “built-up” moulding combinations.

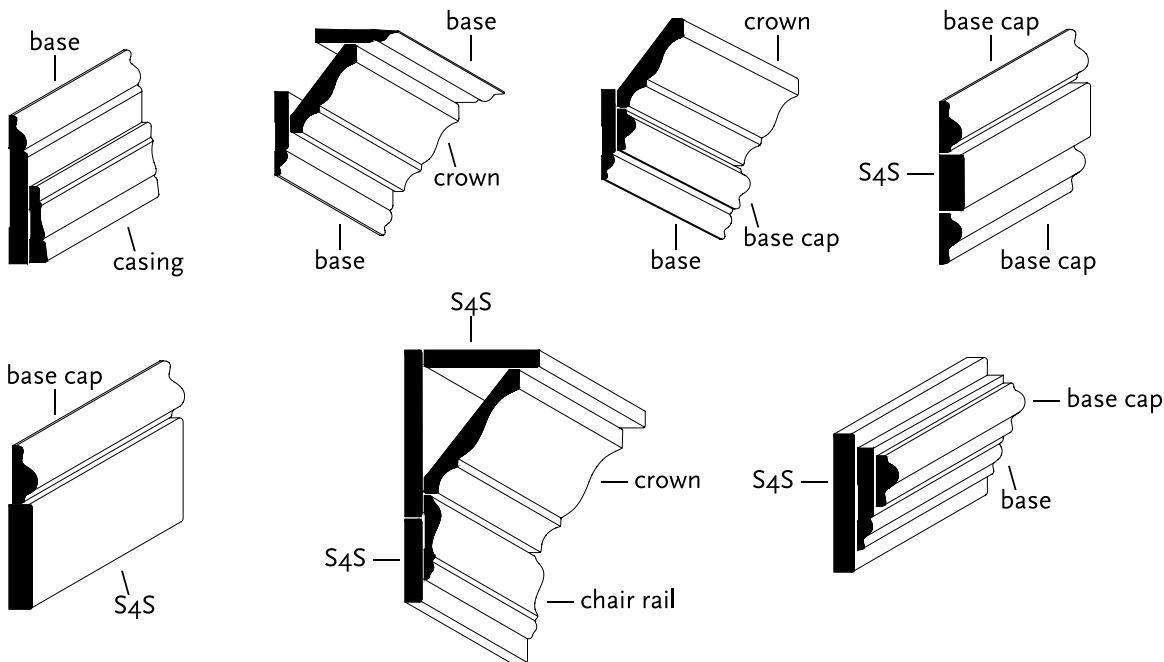

**BASE MOULDING**

**CEILING TREATMENTS**

**CHAIR RAILS**

### EASY TO WORK WITH

Contact Industries' Natural Wood Wrapped Mouldings machine easily and they nail, screw, staple and cut just like softwood. The finger-jointed wood substrate is more dimensionally stable than solid wood, making installation easier. Contact's Natural Wood Wrapped Mouldings are lighter than solid hardwoods or MDF, making it easier to handle and reducing freight costs, time and labor with fewer splices and no pre-drilling.

### PRE-SANDED

Contact Industries' Natural Wood Wrapped Mouldings are pre-sanded, ready for finishing.

### ALSO AVAILABLE PREFINISHED

The smooth, sanded surface is stained, coated twice with sanding sealer, and topcoated with durable polyurethane or a UV cure. Prefinished Natural Wood Wrapped Mouldings provide a winning combination... value, a fine hardwood and high quality factory finish.

### PREMIUM LENGTHS

A key feature of Contact Industries' Natural Wood Wrapped Mouldings is premium lengths. Lineal mouldings are furnished in 14-foot lengths (or 16-foot on request); door unit components in sets and pairs. These premium lengths simplify warehousing and shipping. They also lower the builder's installation cost by reducing waste and labor thanks to fewer splices and no need for pre-drilling.

### READILY AVAILABLE

Contact's Natural Wood Wrapped Mouldings are available in our standard profiles and sizes. Door unit components and mouldings can be shipped in full truckloads or in mixed shipments with other millwork products.

### PROTECTIVE PACKAGING

Contact Industries' Natural Wood Wrapped Mouldings are packaged in protective heavy-duty cartons for ease of shipping, handling, warehousing, and preventing damage.

### COST EFFECTIVE

Contact's Natural Wood Wrapped Mouldings are hardwood moulding products at their best—at a price you can afford. Premium lengths, easier workability, protective packaging, product selection, and availability are features that combine to make Natural Wood Wrapped Mouldings the right choice.

### BAR CODE LABELED

Each piece can be individually bar code labeled.

### OPTIONS

Equalize, dado, rout for hinges and strike, miter, 20-minute fire rating, weather-strip application, any veneer, including exotics.

### ARCHITECTURAL SPECIFICATION

“Interior door jambs and mouldings shall be Natural Wood Wrapped Mouldings as manufactured by Contact Industries.”

End sealing is standard with all wrapped exterior door frame products.

Other sizes, patterns, and species available on special order.

For more details about Natural Wood Wrapped Mouldings and other products from Contact Industries, visit [www.contactind.com](http://www.contactind.com) or call 1-800-547-1038.



9200 SE Sunnybrook Boulevard, Suite 200 • Clackamas, Oregon 97015  
Tel: 503.228.7361 Toll Free: 800.547.1038 • Fax: 503.221.1340 [www.contactind.com](http://www.contactind.com)

